

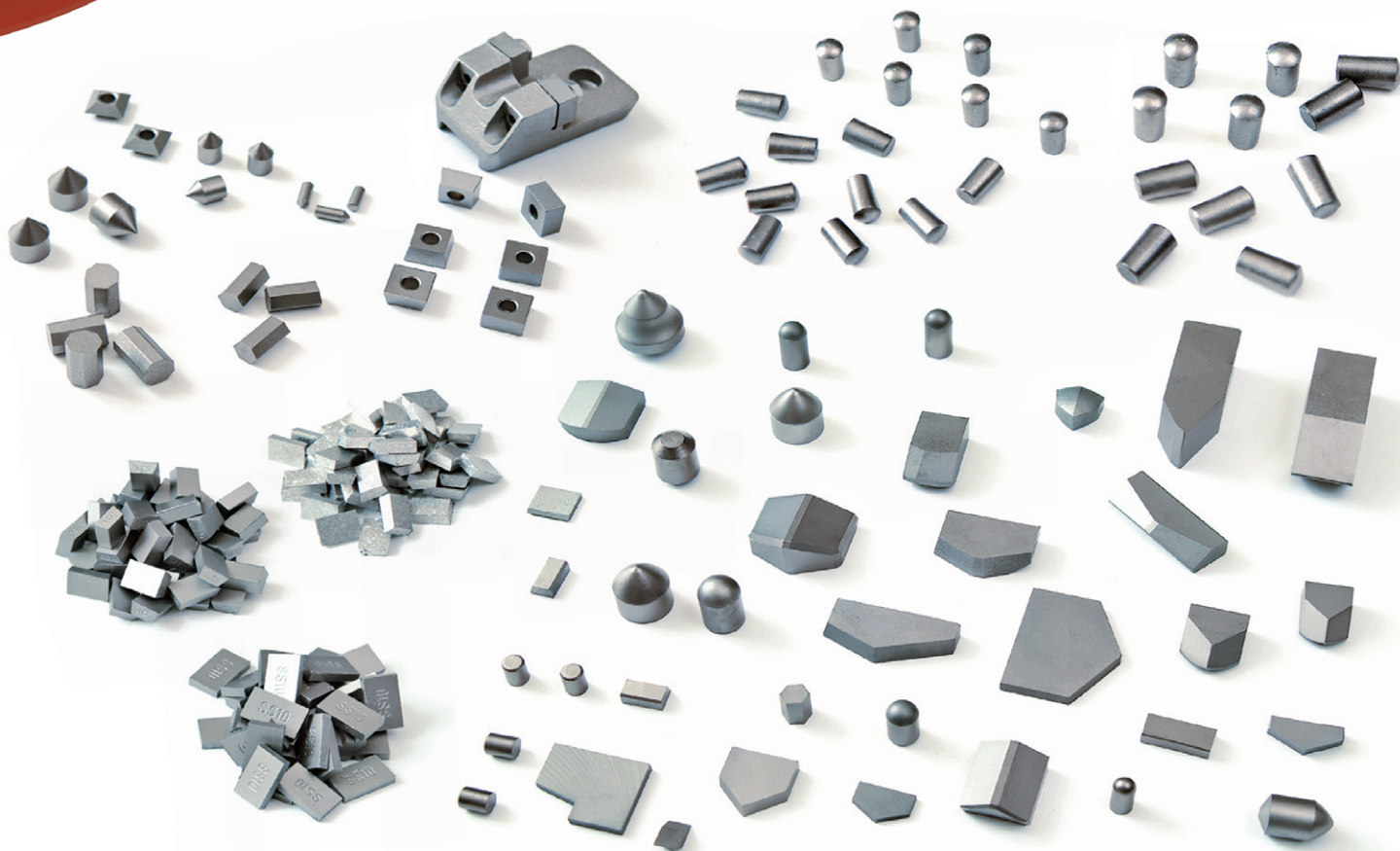

Sinter Sud

metallo**duro**
hardmetal



Hard metal quality manufactory



INDICE

INDEX

INHALTVERZEICHNIS

SOMMAIRE

6° PRISMI ESAGONALI
Hexagonal Prisms
Prismes Hexagonaux
Sechseckige Einsätze
منشورات سداسية.

7° PRISMI OTTAGONALI
Octagonal Prisms
Prismes Octagonaux
Achteckige Einsätze
منشورات ثمانية.

8° PLACCHETTE PER TUFO
Tips for tufa
Plaquettes pour tuf
Einsätze für Tuffstein
أسلحة تقطيع التوفو

9° PLACCHETTE – Tipo C
Tips - Type C
Plaquettes - Modele C
Einsätze - Form C
أسلحة تقطيع التوفو

10° PLACCHETTE PER TUFO RETTANGOLARI
Tips for tufa
Plaquettes pour tuf
Einsätze für Tuffstein
أسلحة تقطيع التوفو

11° PUNTE PER BOCCIARDE
Rods for short drills
Pointes pour bouchardes
Einsätze für Schaftformen
بنط الحفر الغير عميق.

11° PUNTE PER SCALPELLI
Rods for short drills
Pointes pour bouchardes
Schaftformen
رؤوس للأزميل.

12° INSERTI PER SEGATRICI A CATENA
Inserts for chain saw
Inserts pour scies a chaines
Einsätze für Kettensägen
أسنان سلسلة المنشار

14° CUSPIDI A TESTA SFERICA
Cusps
Pointes à tête sphérique
Spitzen
سنون

15° CUSPIDI BALISTICI
Cusps
Pointes à tête balistique
Spitzen
سنون

16° PARTICOLARI SU RICHIESTA DEL CLIENTE
Part on customer's request
Element speciaux sur demande
Sonderteile nach Kundenwunsch
تقصيلات حسب طلب العميل

18° METALLO DURO – QUALITÀ
Hard Metal Grades
Carbure Nuances
Hartmetall Sorten
معدن صلب – الجودة





Dal 1974 **SINTER SUD** realizza prodotti in metallo duro di elevata qualità mediante tecnologie moderne e processi di produzione innovativi.

Trent'anni di continue ricerche permettono all'azienda di produrre un'ampia gamma di prodotti in metallo duro, standard, ovvero personalizzati in base alle specifiche richieste dei clienti. La qualità dei prodotti e l'efficienza dei processi produttivi sono controllate secondo i più severi standard internazionali. Non a caso la **SINTER SUD** ha conseguito le certificazioni ISO 9001 - 2008 e ISO 14001 - 2004.

Dal 2003 tutte le attività produttive si svolgono nel moderno impianto di Sant'Agata Dè Goti che è dotato, infatti, di macchinari all'avanguardia per tecnologia, efficienza ed impatto ambientale.

La notevole capacità produttiva e l'ampia disponibilità di prodotti a stock consentono alla Sinter Sud di soddisfare in tempi brevi le più diverse esigenze dei clienti.

In **SINTER SUD** ognuno è consapevole dell'importanza della soddisfazione del cliente, unico vero patrimonio dell'azienda. Tecnologia, qualità, professionalità ed affidabilità sono gli elementi fondamentali del nostro rapporto con i clienti.

SINTER SUD è oggi una tra le aziende leader nel settore del metallo duro nel mondo. Così come in passato, la passione per il nostro lavoro anima la volontà di progredire insieme ai nostri clienti e ci spinge ad accettare sempre nuove sfide tecnologiche nel campo del metallo duro.

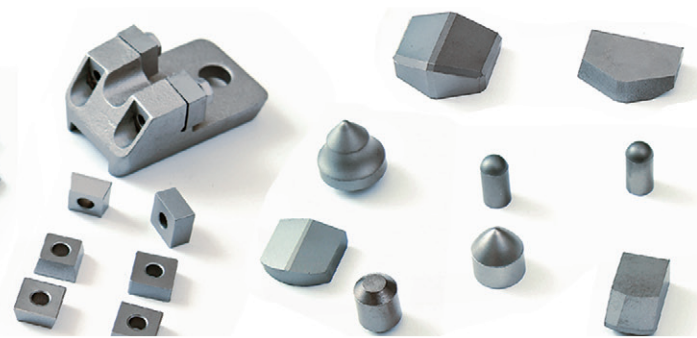
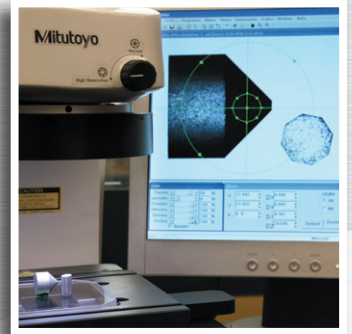

RAW MATERIAL DEPT.



Seit 1974 stellt die Firma **SINTER SUD** durch moderne Technologie und erneuernde Produktionsprozesse Hochqualität Hartmetallprodukte her.

Dreissig Jahre Produktforschung ermöglicht **SINTER SUD** eine grosse Wahl von VHM Produkte, beide nach DIN Norm und nach Kunden Zeichnung, anzubieten. Die Qualität der Artikeln und die Leistungsfähigkeit der Produktionsanlage werden immer intensiv nach den höchsten internationalen Standards kontrolliert: die Firma ist nach ISO 9001 – 2008 und ISO 14001 – 2004 zertifiziert.

Vom Jahr 2003 finden alle Produktionstätigkeiten im modernsten Produktionsstandort in der Nähe von Sant'Agata Dè Goti (BN) statt.

Dank der beachtlichen Produktionsfähigkeit und der breiten Verfügbarkeit von grossen Artikelmenen auf Lager, können die Erfordernisse der Kunden schnell befriedigt werden.

Jeder weiss im **SINTER SUD** die Wichtigkeit der Befriedigung des Kunden, der die einzige echte Erbe der Firma wirklich ist. Technologie, Qualität, Professionalität und Zuverlässigkeit sind die Grundelemente unserer Beziehungen mit den Kunden.

SINTER SUD ist heute weltweit der Marktführer in der Hartmetallindustrie. Die Leidenschaft für unsere Arbeit ist die Wille mit unseren Kunden zu entwickeln und immer neue technologischen Herausforderungen im Feld des Hartmetalls anzunehmen.



Since 1974 **SINTER SUD** has been manufacturing premium quality hard metal items, through modern technologies and innovative production processes.

Thanks to thirty years of continuous R&D activities **SINTER SUD** produces a wide range of excellent hard metal products, both standard or customized in accordance with customers' different needing. Product quality and process efficiency are always checked in accordance with the strictest international standards: **SINTER SUD** is ISO 9001 - 2008 and ISO 14001 - 2004 certified.

In 2003, the company moved to the new modern plant located in Sant'Agata Dè Goti (BN) which is equipped with new up-to-date machineries, leading the way in technology, efficiency and environmental impact.

The remarkable, manufacturing capability and the wide range of items ready on stock, permits **SINTER SUD** to satisfy even the most exciting customers promptly.

Every one in **SINTER SUD** is aware of customer satisfaction is the only wealth of the company. Technology, quality, skillness and reliability are priorities in the customers' company partnership.

SINTER SUD is now one of the world's hard metal leader; since its origins the passion for our work builds the will to improve together with our customers and drives us to face the new technological hard metal challenges.

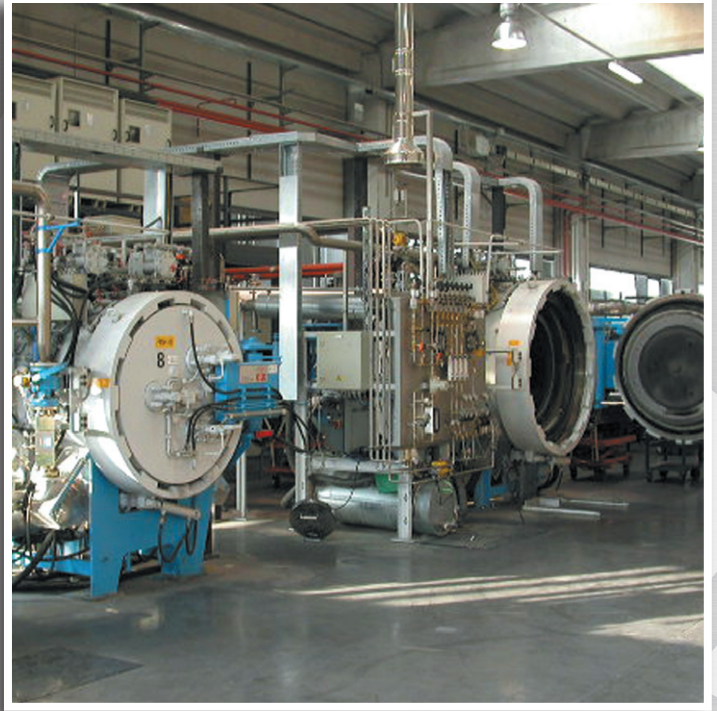

PRESS DEPARTMENT



GRINDING DEPARTMENT



Depuis 1974 **SINTER SUD** produit des composants en métal dur de haute qualité avec des technologies modernes et innovantes.

Trente ans d'expérience de recherche et l'évolution continue permet de produire une large gamme d'articles en métal dur, standards et personnalisés selon demandes des clientes. Le contrôle de qualité des nos produits et l'efficacité des nos processus répondent aux plus sévères normes internationales : **SINTER SUD** est certifié ISO 9001 - 2008 et ISO 14001 - 2004.

A partir de 2003 toutes les activités de production sont concentrées dans le nouveau site de production de Sant'Agata Dè Goti (BN) qui est équipée avec des machines technologiquement avancées, efficaces et respectueux de l'environnement.

L'importante capacités de production et un grand quantité des articles déjà disponibles en stock, permettent de satisfaire les différentes demandes des clientes rapidement.

Chacun in **SINTER SUD** est conscient que la satisfaction du client représente le patrimoine de l'entreprise. Technologie, qualité, professionnalisme et fiabilité sont les éléments centraux notre partenariat avec les clientes.

SINTER SUD est aujourd'hui leader mondial dans le secteur du métal dur. La passion de notre métier alimente tout jour la volonté de croître avec nos clientes et nous encourage à relever les défis incessants de la technologie dans le domaine de carbure.

PRISMI ESAGONALI

Hexagonal Prisms

Prismes Hexagonaux

Sechseckige Einsätze

منشورات سداسية

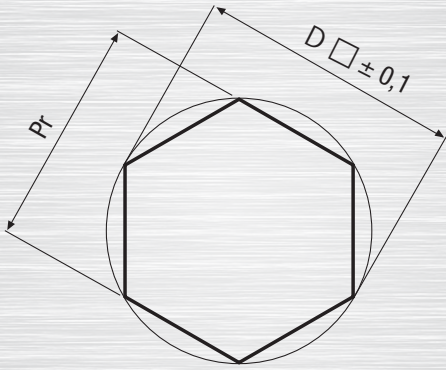

GRADO GRADE SORTE NUANCE			SS10	K30
Pr mm	D mm	L mm	CODICE ARTICOLO ARTICLE CODE CODE ARTICLE CODE ARTIKEL	CODICE ARTICOLO ARTICLE CODE CODE ARTICLE CODE ARTIKEL
5,0	5,77	16	SS10PE05016	K30PE05016
7,5	8,66	16	SS10PE07516	K30PE07516
10,0	11,55	16	SS10PE10016	K30PE10016
14,5	16,74	20	SS10PE14520	K30PE14520



PRISMI OTTOGONALI

Octagonal Prisms

Prismes Octagonaux

Achteckige Einsätze

منشورات ثمانية

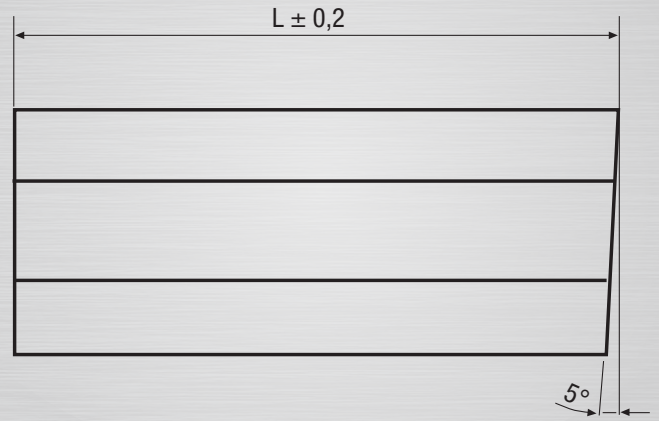
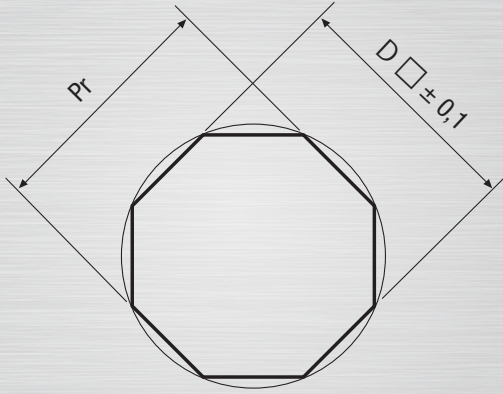

GRADO GRADE SORTE NUANCE			SS10	K30
Pr mm	D mm	L mm	CODICE ARTICOLO ARTICLE CODE CODE ARTICLE CODE ARTIKEL	CODICE ARTICOLO ARTICLE CODE CODE ARTICLE CODE ARTIKEL
5,5	5,95	16	SS10P005516	K30P005516
6,0	6,49	16	SS10P006016	K30P006016
7,5	8,12	16	SS10P007516	K30P007516
9,5	10,20	16	SS10P009516	K30P009516
10,0	10,82	16	SS10P010016	K30P010016
12,0	12,98	16	SS10P012016	K30P012016

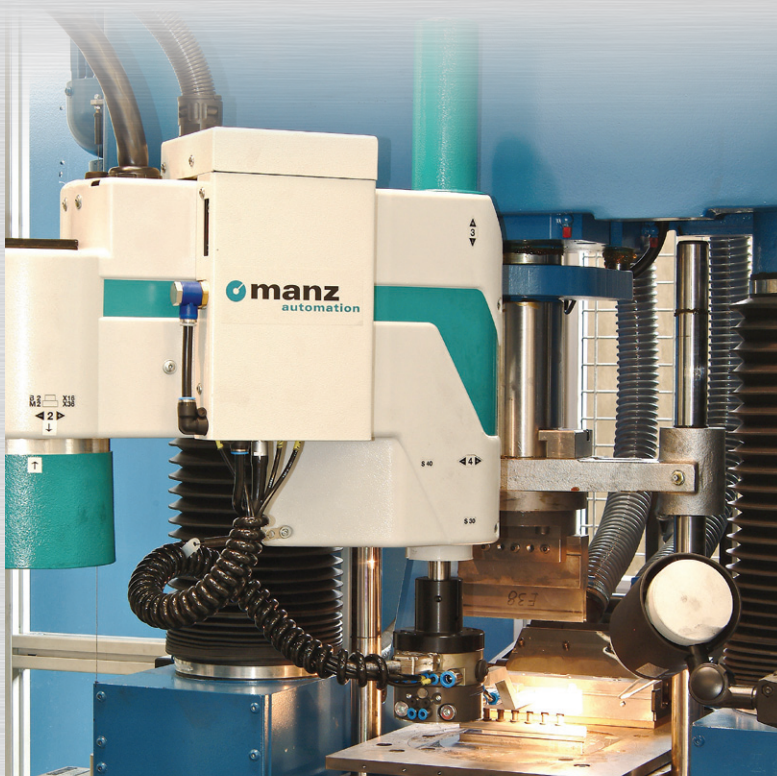

PLACCHETTE PER TUFO

Tips for tufa

Plaquettes pour tuf

Einsätze für tuffstein

أسلحة تقطيع التوفو

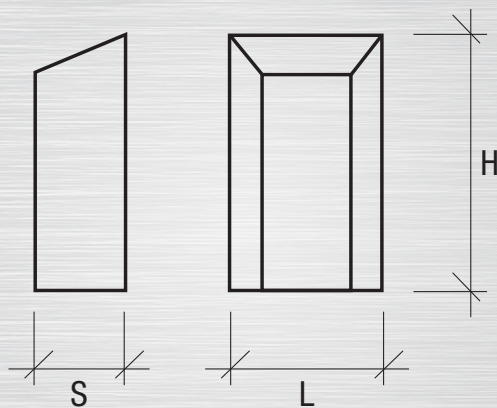

GRADO GRADE SORTE NUANCE			SS6	SS10	K30P	SG2
H mm	L mm	S mm	CODICE ARTICOLO ARTICLE CODE CODE ARTICLE CODE ARTIKEL	CODICE ARTICOLO ARTICLE CODE CODE ARTICLE CODE ARTIKEL	CODICE ARTICOLO ARTICLE CODE CODE ARTICLE CODE ARTIKEL	CODICE ARTICOLO ARTICLE CODE CODE ARTICLE CODE ARTIKEL
12	8	4	SS6P12084	SS10P12084	K30P12084	SG2P12084
15	10	4	SS6P15104	-	K30P15104	SG2P15104
13	10	5	SS6P13105	SS10P13105	K30P13105	SG2P13105
15	10	5	SS6P15105	SS10P15105	K30P15105	SG2P15105

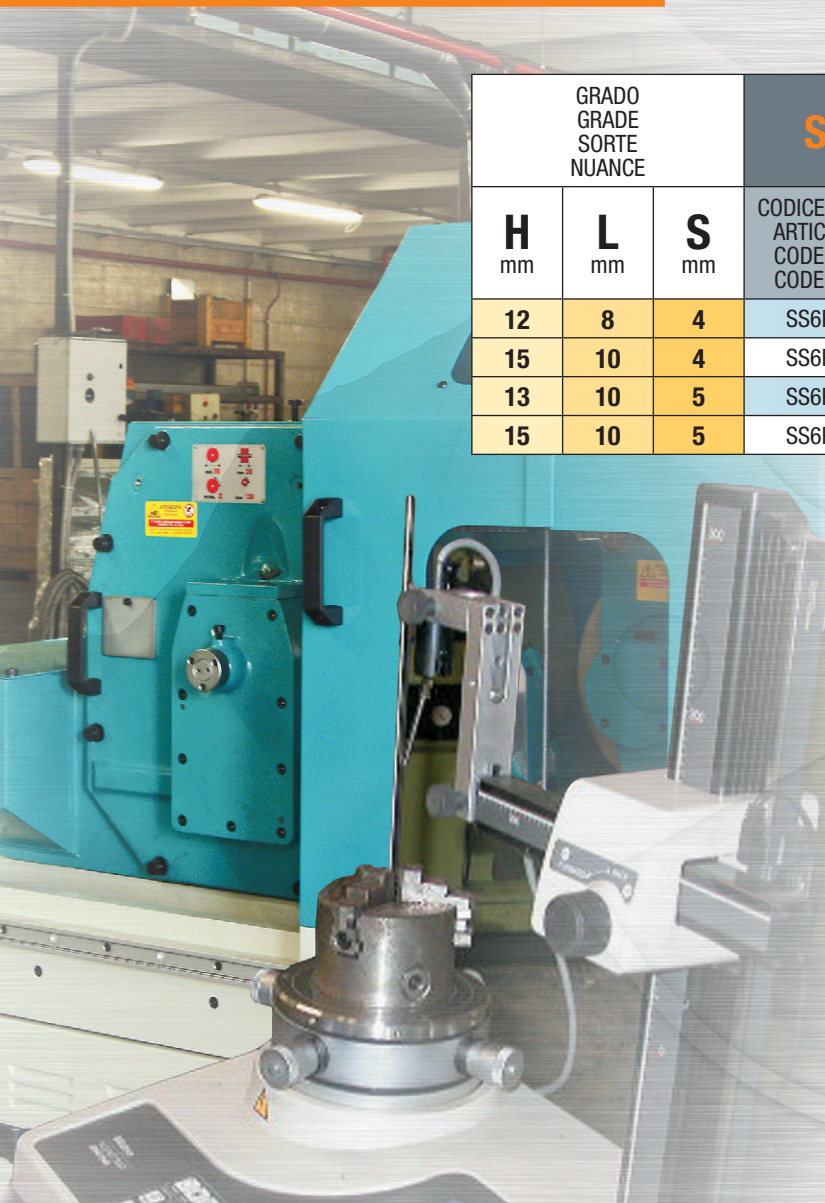

PLACCHETTE - Tipo C

Tips - Type C

Plaquettes - Modele C

Einsätze - Form C

أسلحة تقطيع التوفو

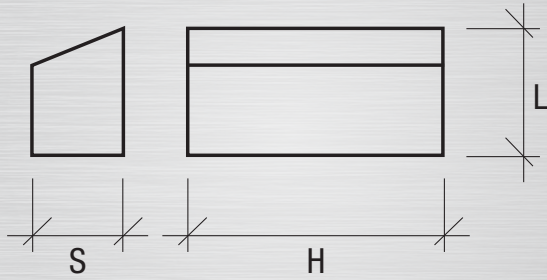

GRADO GRADE SORTE NUANCE			SS6	SS10	K30P
H mm	L mm	S mm	CODICE ARTICOLO ARTICLE CODE CODE ARTICLE CODE ARTIKEL	CODICE ARTICOLO ARTICLE CODE CODE ARTICLE CODE ARTIKEL	CODICE ARTICOLO ARTICLE CODE CODE ARTICLE CODE ARTIKEL
12	8	5	SS6PC12	SS10PC12	K30PC12
12	10	4	SS6PC12.10	SS10PC12.10	K30PC12.10
16	10	6	SS6PC16	SS10PC16	K30PC16
20	12	7	SS6PC20	SS10PC20	K30PC20

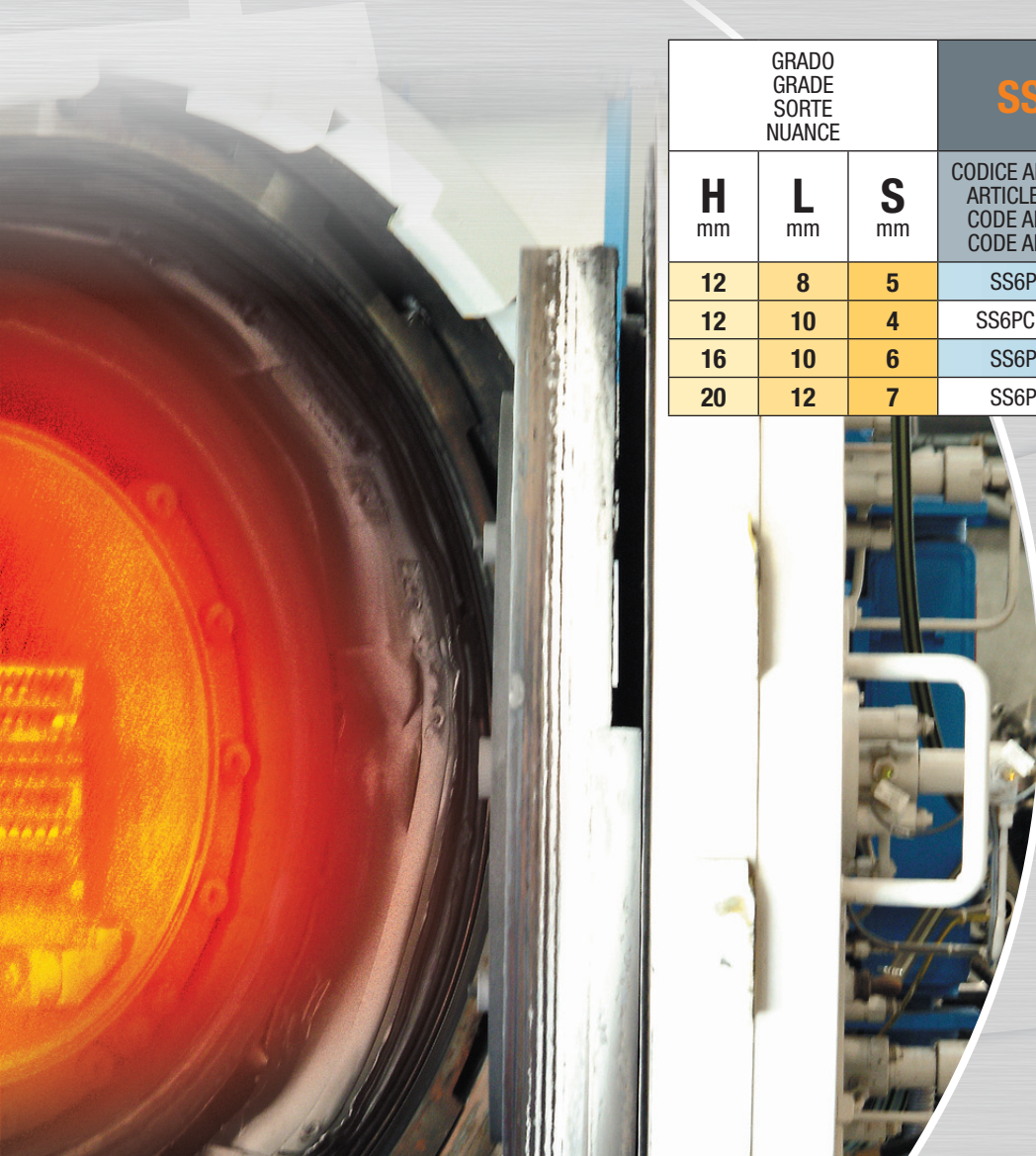

PLACCHETTE

PER TUFO RETTANGOLARI

Tips for tufa

Plaquettes pour tuf

Einsätze für tuffstein

أسلحة تقطيع التوفو

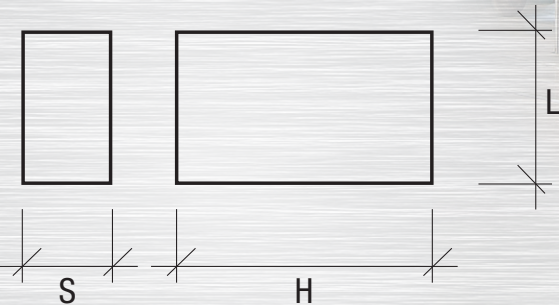

GRADO GRADE SORTE NUANCE			SG2	SS10	SS20	K30P
H mm	L mm	S mm	CODICE ARTICOLO ARTICLE CODE CODE ARTICLE CODE ARTIKEL	CODICE ARTICOLO ARTICLE CODE CODE ARTICLE CODE ARTIKEL	CODICE ARTICOLO ARTICLE CODE CODE ARTICLE CODE ARTIKEL	CODICE ARTICOLO ARTICLE CODE CODE ARTICLE CODE ARTIKEL
16	12	3,0	SG2P161230	SS10P161230	SS20P161230	K30P161230
18	12	3,0	SG2P181230	SS10P181230	SS20P181230	K30P181230
18	12	3,5	SG2P181235	SS10P181235	SS20P181235	K30P181235
20	12	3,0	SG2P201230	SS10P201230	SS20P201230	K30P201230
20	12	3,5	SG2P201235	SS10P201235	SS20P201235	K30P201235

PUNTE DRITTE PER BOCCIARDE

Rods for short drills

Pointes pour bouchardes

Shaftformen

بنط الحفر الغير عميق.



GRADO GRADE SORTE NUANCE		K30
D mm	H mm	CODICE ARTICOLO ARTICLE CODE CODE ARTICLE CODE ARTIKEL
2,5	10	K30 PB02510
3,0	10	K30 PB03010
4,0	8	K30 PB04008
4,0	12	K30 PB04012
5,0	8	K30 PB05008
5,0	13	K30 PB05013
6,0	8	K30 PB06008
6,0	10	K30 PB06010
6,0	13	K30 PB06013
8,0	12	K30 PB08012
9,0	14	K30 PB09014
10,0	18	K30 PB10018
12,0	15	K30 PB12015

PUNTE CONICHE PER BOCCIARDE

Conic rods for short drills

Pointes cuonic pour bouchardes

Shaftformen

بنط الحفر الغير عميق.

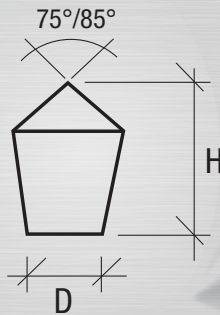

GRADO GRADE SORTE NUANCE		K30
D mm	H mm	CODICE ARTICOLO ARTICLE CODE CODE ARTICLE CODE ARTIKEL
4,40	7	K30 PC04407
4,60	9	K30 PC04609
6,50	9	K30 PC06590

PUNTE A PIRAMIDE PER BOCCIARDE

Rods for short drills

Pointes pour bouchardes

Shaftformen

بنط الحفر الغير عميق.

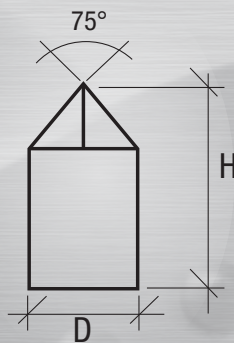

GRADO GRADE SORTE NUANCE		K30
D mm	H mm	CODICE ARTICOLO ARTICLE CODE CODE ARTICLE CODE ARTIKEL
6,00	8	K30 PP06008
6,00	10	K30 PP06010
8,00	10	K30 PP08010

PUNTE PER SCALPELLI

Ends for chisel

Pointes pour ciseaux

Schlageisen

رؤوس للأزاميل.

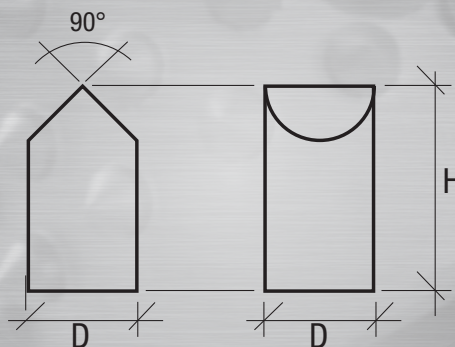

GRADO GRADE SORTE NUANCE		K30
D mm	H mm	CODICE ARTICOLO ARTICLE CODE CODE ARTICLE CODE ARTIKEL
5,00	15	K30 PS05015
7,00	15	K30 PS07015
9,00	16	K30 PS09016

INSERTI PER SEGATRICI A CATENA

Inserts for chain saw

Inserts pour scies a chaines

Einsätze für kettesägen

أسنان سلسلة المنشار

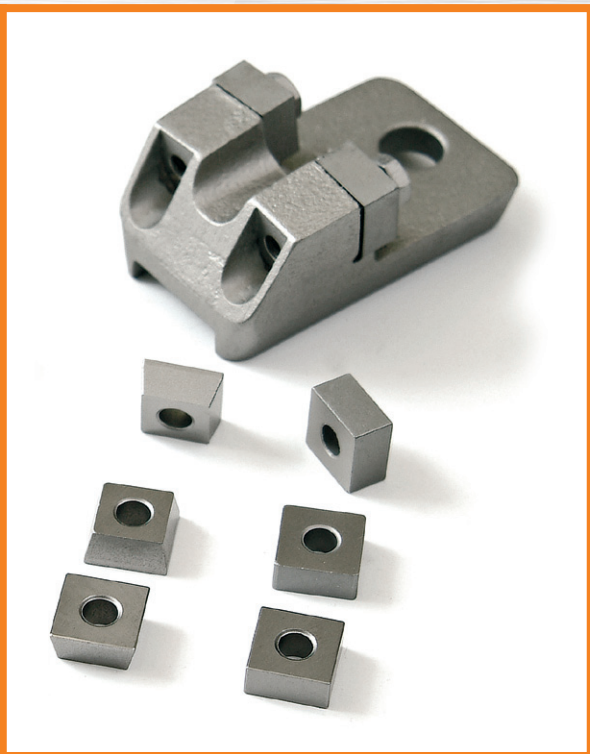

Kind F

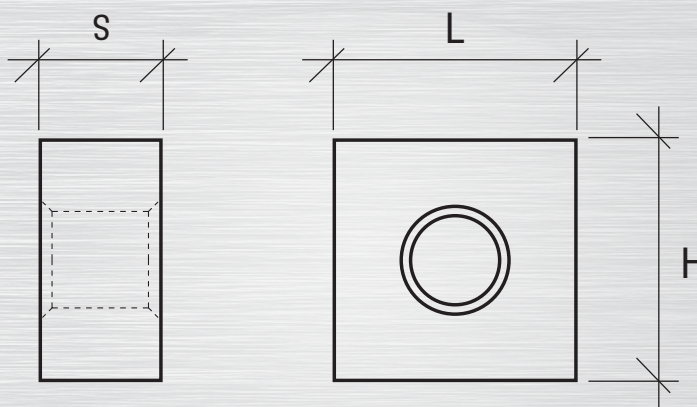

GRADO GRADE SORTE NUANCE			SS6	SS10	K20	K30
H mm	L mm	S mm	CODICE ARTICOLO ARTICLE CODE CODE ARTICLE CODE ARTIKEL	CODICE ARTICOLO ARTICLE CODE CODE ARTICLE CODE ARTIKEL	CODICE ARTICOLO ARTICLE CODE CODE ARTICLE CODE ARTIKEL	CODICE ARTICOLO ARTICLE CODE CODE ARTICLE CODE ARTIKEL
GREZZO - UNGROUND - BRUT						
12.7	12.7	6	SS6IFG12706	SS10IFG12706	K20IFG12706	K30IFG12706
RETTIFICATO - GROUND - RECTIFIE						
12.7	12.7	6	SS6IFR12706	SS10IFR12706	K20IFR12706	K30IFR12706
GREZZO - UNGROUND - BRUT						
13	13	7	SS6IFG13007	SS10IFG13007	K20IFG13007	K30IFG13007
RETTIFICATO - GROUND - RECTIFIE						
13	13	7	SS6IFR13007	SS10IFR13007	K20IFR13007	K30IFR13007

INSERTI PER SEGATRICI A CATENA

Inserts for chain saw

Inserts pour scies a chaines

Einsätze für kettesägen

أسنان سلسلة المنشار

Kind K

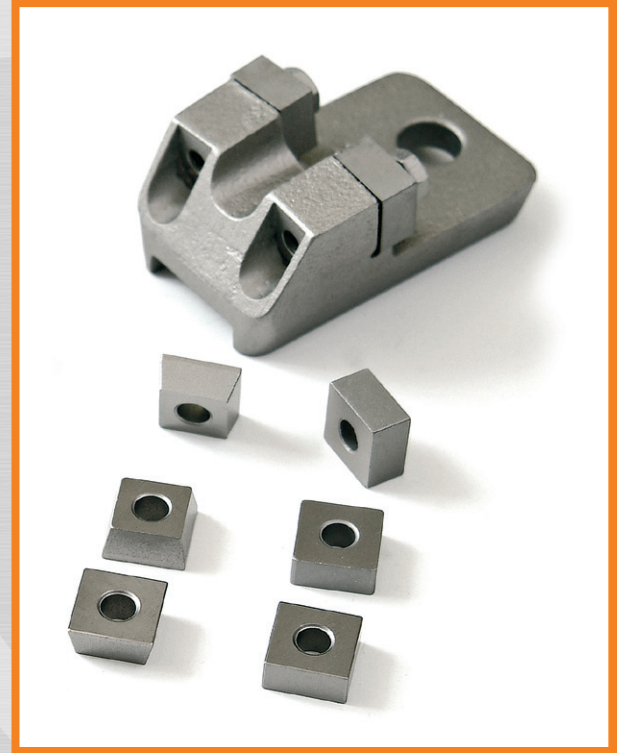
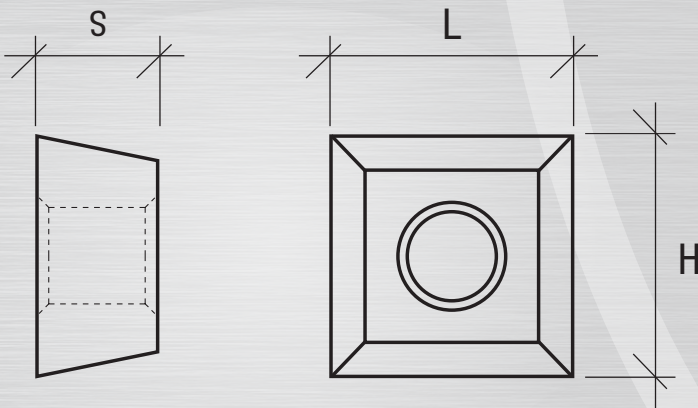

GRADO GRADE SORTE NUANCE			SS6	SS10	K20	K30
H mm	L mm	S mm	CODICE ARTICOLO ARTICLE CODE CODE ARTICLE CODE ARTIKEL	CODICE ARTICOLO ARTICLE CODE CODE ARTICLE CODE ARTIKEL	CODICE ARTICOLO ARTICLE CODE CODE ARTICLE CODE ARTIKEL	CODICE ARTICOLO ARTICLE CODE CODE ARTICLE CODE ARTIKEL
GREZZO - UNGROUND - BRUT						
12.7	12.7	6	SS6IKG12706	SS10IKG12706	K20IKG12706	K30IKG12706
RETTIFICATO - GROUND - RECTIFIE						
12.7	12.7	6	SS6IKR12706	SS10IKR12706	K20IKR12706	K30IKR12706

CUSPIDI

A TESTA SFERICA

Cusps

Pointes à tête sphérique

Spitzen

سنون



GRADO GRADE SORTE NUANCE		SS6	SS10	K30
D mm	H mm	CODICE ARTICOLO ARTICLE CODE CODE ARTICLE CODE ARTIKEL	CODICE ARTICOLO ARTICLE CODE CODE ARTICLE CODE ARTIKEL	CODICE ARTICOLO ARTICLE CODE CODE ARTICLE CODE ARTIKEL
8	18	SS6CR0818	SS10CR0818	K30CR0818
10	18	SS6CR1018	SS10CR1018	K30CR1018
12	20	SS6CR1220	SS10CR1220	K30CR1220
14	24	SS6CR1424	SS10CR1424	K30CR1424
16	24	SS6CR1624	SS10CR1624	K30CR1624
19	26	SS6CR1926	SS10CR1926	K30CR1926
22	32	SS6CR2232	SS10CR2232	K30CR2232

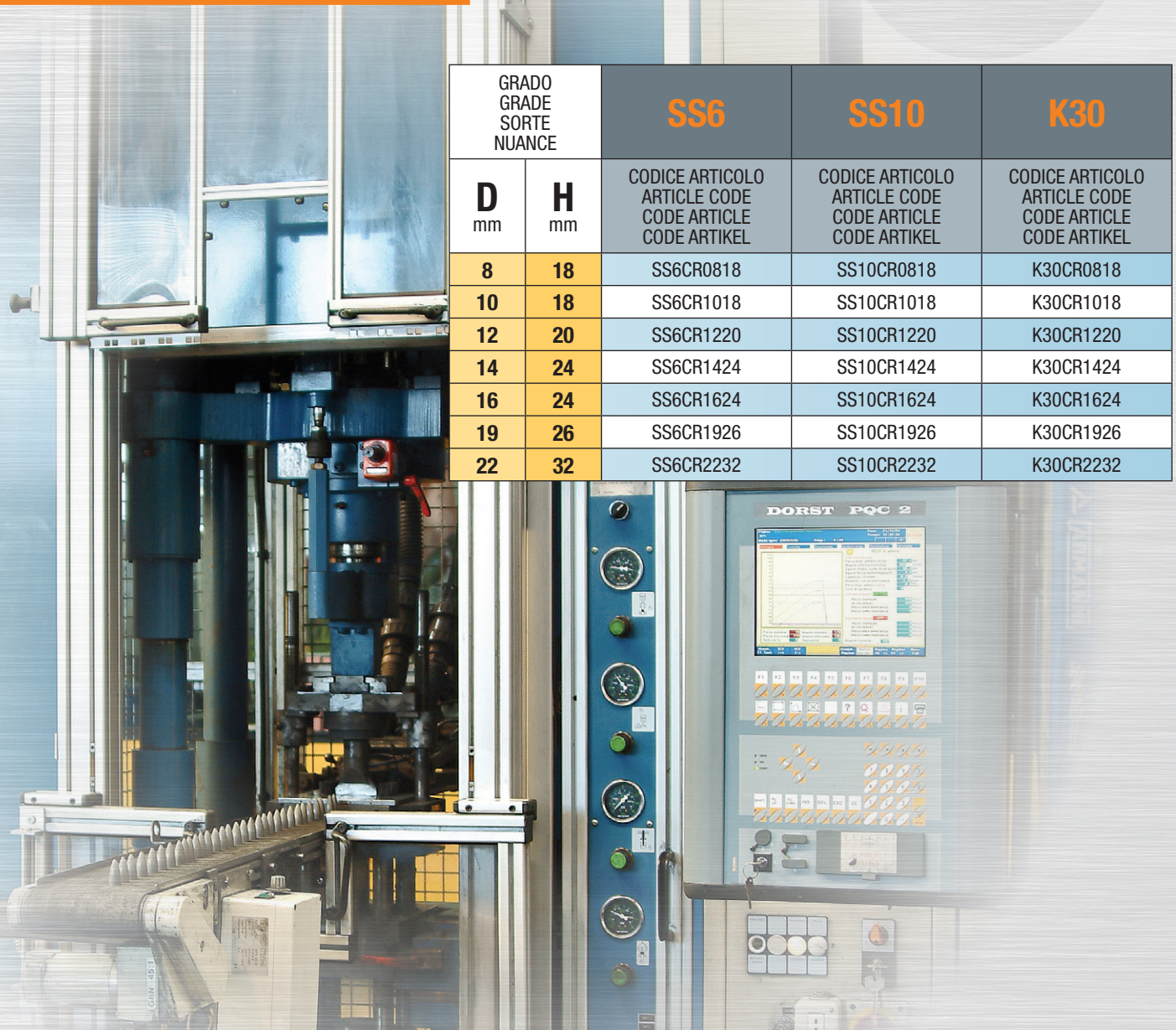

CUSPIDI BALISTICI

Cusps

Pointes à tête balistique

Spitzen

سنون

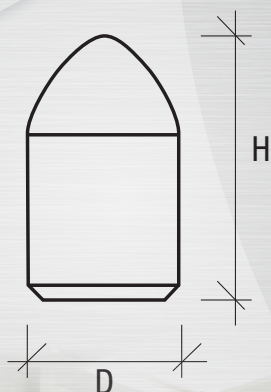

GRADO GRADE SORTE NUANCE		SS6	SS10	K30
D mm	H mm	CODICE ARTICOLO ARTICLE CODE CODE ARTICLE CODE ARTIKEL	CODICE ARTICOLO ARTICLE CODE CODE ARTICLE CODE ARTIKEL	CODICE ARTICOLO ARTICLE CODE CODE ARTICLE CODE ARTIKEL
8	16	SS6CB0816	SS10CB0816	K30CB0816
10	18	SS6CB1018	SS10CB1018	K30CB1018
12	24	SS6CB1224	SS10CB1224	K30CB1224
14	24	SS6CB1424	SS10CB1424	K30CB1424
16	25	SS6CB1625	SS10CB1625	K30CB1625
19	30	SS6CB1930	SS10CB1930	K30CB1930
22	35	SS6CB2235	SS10CB2235	K30CB2235



PARTICOLARI SU RICHIESTA DEL CLIENTE

Part on customer's request

Element speciaux sur demande

Sonderteile nach Kundenwunsch

تفصيلات حسب طلب العميل

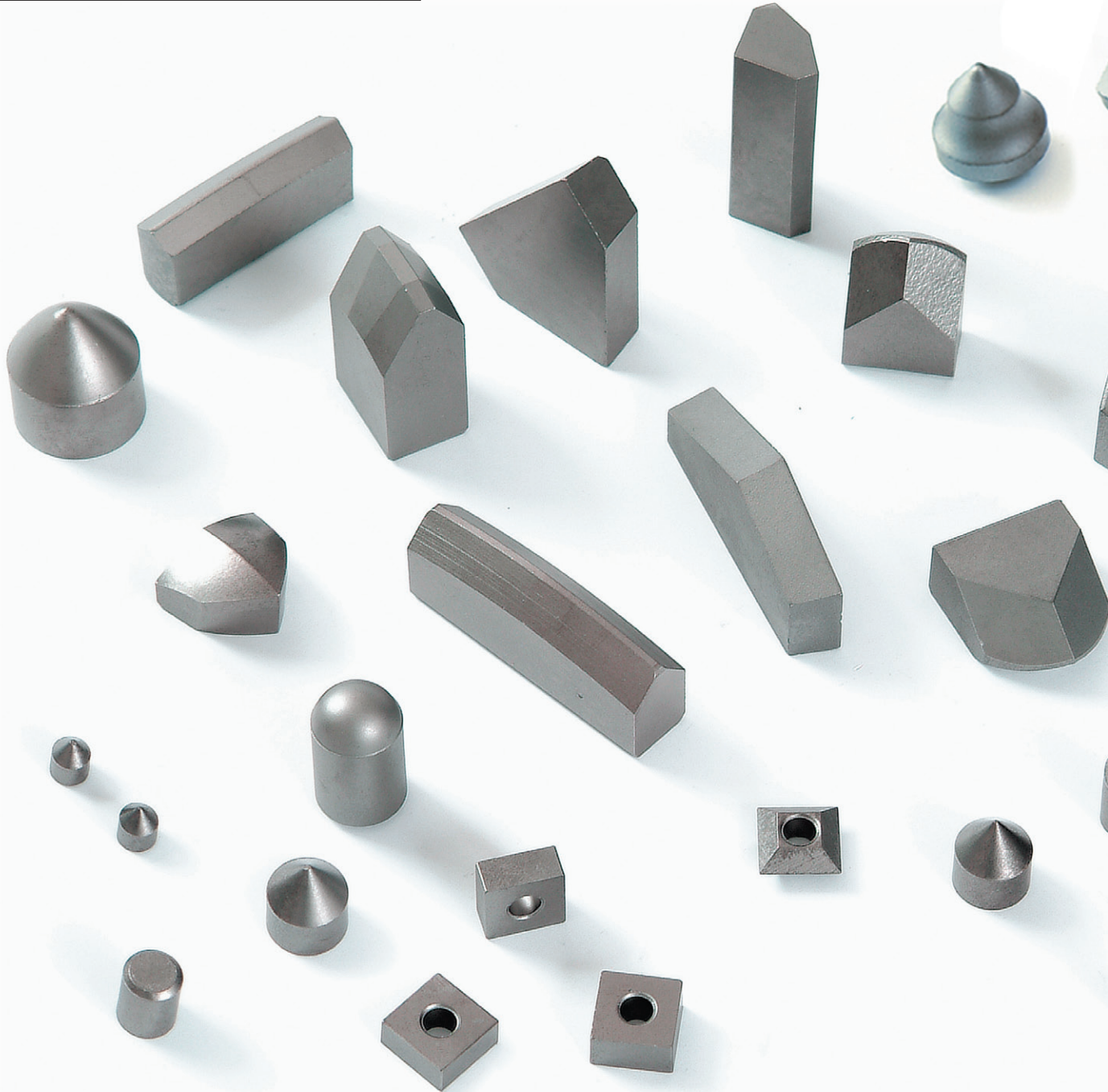

PARTICOLARI SU RICHIESTA DEL CLIENTE

Part on customer's request

Element speciaux sur demande

Sonderteile nach Kundenwunsch

تفصيلات حسب طلب العميل

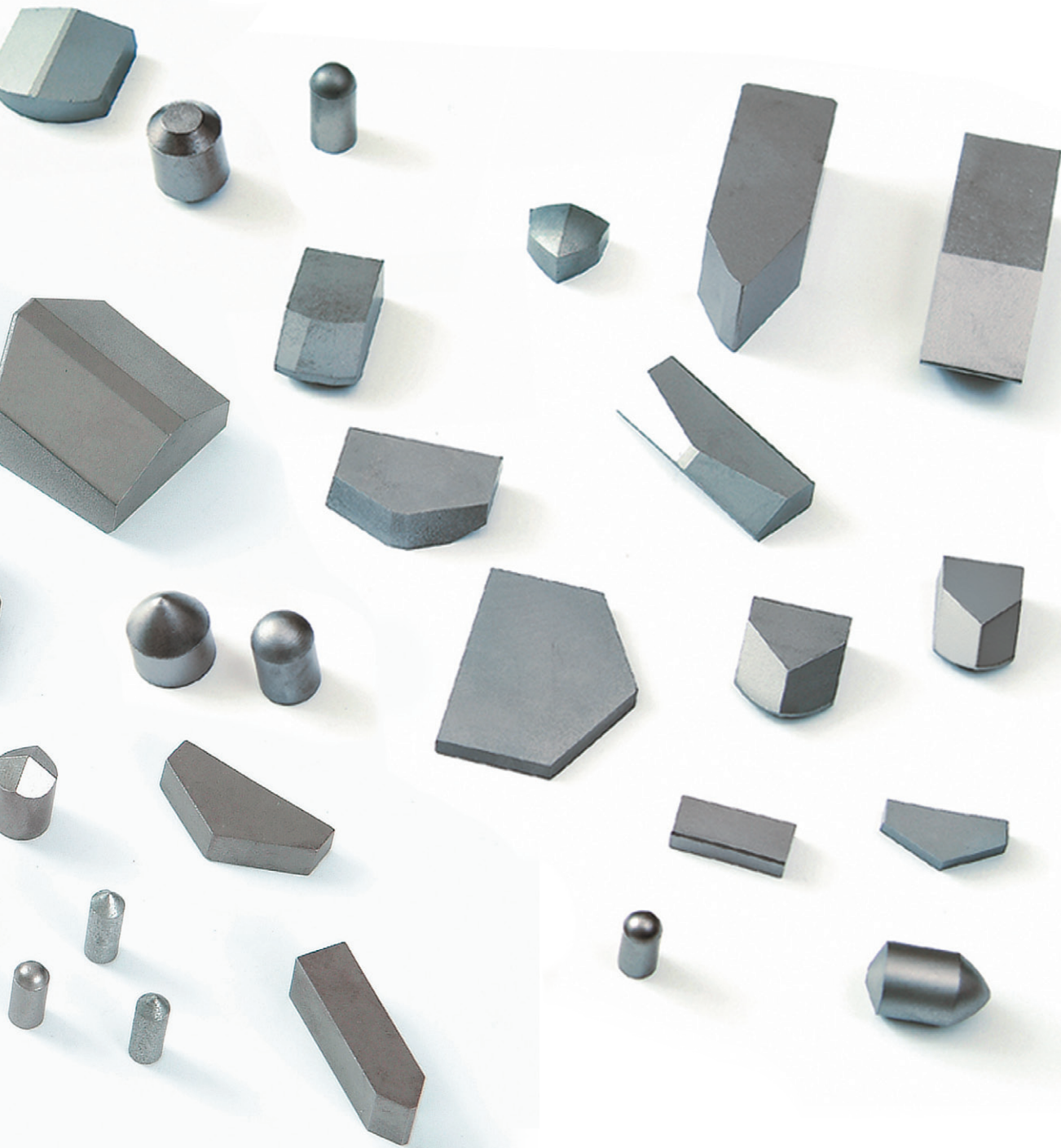

SS6

Grado di elevata durezza. Adatto per l'estrazione di pietre marmoree e perforazione di rocce ad elevata durezza ed omogeneamente compatte.

Hard grade. It is suitable for marble quarrying and for boring of homogeneous very hard rock.

Nuance à dureté élevée. Adaptée à l'extraction du marbre et à la perforation de roches dures, homogènes et compactes.

HM-Sorte mit höher Härte. Die SS6 Sorte ist für die Förderung von Marmorstein und für die Durchbohrung von festen und gleichartigen Gesteine geeignet.

المرتفعة والأحجار المدمجة عالية التجانس. درجة عالية الصلابة ، ومناسبة لاستخراج أحجار الرخام وحفر الصخور ذات الصلابة

SS10

Grado a media durezza e buona tenacità. Adatto per l'estrazione di pietre marmoree e perforazione di rocce disomogenee a media durezza.

Medium-hard grade with high tenacity. It is suitable for marble quarrying and non-homogeneous medium hard rock drilling.

Nuance à dureté moyenne et bonne ténacité. Adaptée à l'extraction du marbre et la perforation de roches inhomogènes de dureté moyenne.

HM-Sorte mit medium Härte und hoher Zährtigkeit. Die SS10 Sorte ist für die Förderung von Marmorstein und für die Durchbohrung von medium-harten und ungleichartigen Gesteine geeignet.

الصخور الغير متجانسة ذات الصلابة المتوسطة. درجة متوسطة الصلابة وذات متانة جيدة ، ومناسب لاستخراج أحجار الرخام وحفر

SS20

Grado adatto ad applicazioni di tipo minerario dove è richiesta una elevata tenacità e grande resistenza alle sollecitazioni meccaniche. Adatto anche per asportazioni di asfalto.

This grade is suitable for medium compact rocks drilling and working. It is suitable also for asphalt removing.

Nuance adaptée au forage géologique. Dureté élevée et grande résistance mécanique. Aussi utilisée dans l'enterement de l'asphalte.

HM-Sorte, die für die bergbauliche Anwendungen, die hohe Zährtigkeit und Schlegfestigkeit benötigen, geeignet ist. SS20 ist auch für die Fortschaffung von Asphalte.

الميكانيكي ، ومناسبة أيضا لانتزاع طبقة الإسفلت. درجة مناسبة للتطبيقات لأعمال المناجم حيث تتطلب متانة عالية ومقاومة شديدة للإجهاد

K30P

Grado con grande resistenza all'usura. Adatto per l'estrazione di pietre abrasive a media durezza.

Very wear-resistant grade. It is suitable for abrasive medium hard rocks quarrying.

Nuance avec grande résistance à l'usure. Adaptée à l'extraction du pierre abrasive à dureté moyenne.

HM-Sorte mit höher Verschleißfestigkeit. Die Sorte K30P ist für die Förderung von abschleifenden, medium-festen Gesteine geeignet.

المتوسطة. درجة ذات مقاومة كبيرة للتآكل ، ومناسبة لاستخراج حجارة التخليخ ذات الصلابة

SG2 - SG3

Grado ad elevata tenacità. Adatto per perforazioni e lavorazioni di rocce disomogenee a media durezza.

Very tough grade. It is suitable for non-homogeneous medium-hard rocks boring and working.

Nuance à tenacité élevée. Adaptée à la perforation et au travail de roches inhomogènes et de dureté moyenne.

HM-Sorte mit höher Zährtigkeit. Die Sorte SG3 ist für die Durchbohrung und Bearbeitung von medium-harten und ungleichartigen Gesteine geeignet.

المتوسطة. درجة عالية المتانة ، مناسبة لأعمال الحفر وتشكيل الصخور الغير متجانسة ذات الصلابة

K20

Grado ad elevata durezza. Adatto per l'estrazione di pietre marmoree e similari.

Hard grade. It is suitable for marble and similar stones.

Nuance à dureté élevée. Adaptée à l'extraction du Marbre et de pierre similaires.

HM-Sorte mit höher Härte. Die Sorte K20 ist für die Förderung von Marmor verschiedene gesteine.

درجة عالية الصلابة ، مناسبة في استخراج أحجار الرخام وما شابهها.

K30

Grado ad elevata durezza. Adatto per l'estrazione di travertino e pietre similari, inoltre largamente usato per utensili a bocciardare.

Hard grade. It is suitable for travertine and similar stones quarrying and for bushammers.

Nuance à dureté élevée. Adaptée à l'extraction du travertin et de pierre similaires. Egalment utilisé pour outils de bouchardage.

HM-Sorte mit höher Härte. Die Sorte K30 ist für die Förderung von Travertin und ähnliche Gesteine geeignet.

أدوات الحفر. درجة عالية الصلابة ، ومناسبة لاستخراج حجارة الترافرتين وما يشابهها من أحجار وفي

ماكينات ومعدات لقطع وقص الحجارة

إستشيرونا

إنتاج بلوكات لقص الحجارة - والرخام

إنتاج ماكينات لقص الحجارة المسامية. إستيراد وتصدير أفكاركم

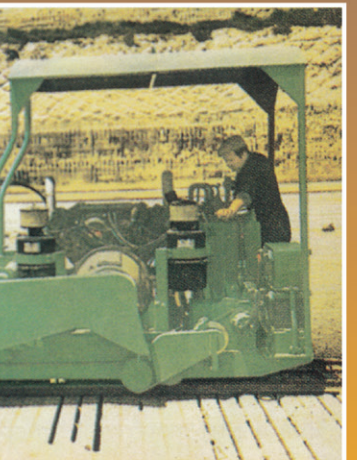
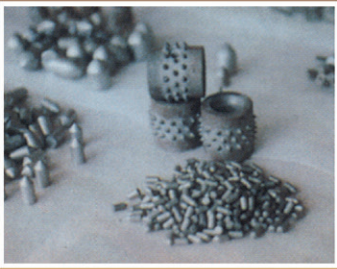

تعمل شركة MECCANOTEC في حقل إنتاج ماكينات لقطع الحجارة المسامية. وبيع كافة قطع
القيار اللازمة لها ك: الإسطوانات (التي يتم خام البلوكات عليها)، وسامد، دعائم، عارضات وقواطع،
... وغيرها.

تتابع أبحاث السوق لتتمكن من تحقيق أي نوع من الطلبات التي تقدم إليها في نطاق عملها
وتختص أيضاً في حقل إنتاج ماكينات أعمال الشوارع والطرق.

تتعامل شركة SINTER - SUD , MECCANOTEC مع الأسواق العربية منذ عام ١٩٧٤،
وطالما تميزا بمهليتهما وبنوعية الأعمال التي يقدمانها .

تعمل SINTER - SUD في حقل إنتاج بلوكات لقص وقطع الحجارة، كالحجارة المسامية والرخام،
بلوكات لأكابيل ومستار الحفر والثقب، سهام بروس تأخذ شكل ثلاثي مدب لأعمال الشوارع
والطرق، مطارق بروس حديدية للرخام والجرايت.



Sinter Sud srl

Uffici e Stabilimento/Factory:

Zona Ind.le loc. Capitone
82019 Sant'Agata De'Goti
(Benevento) - Italy

Amministrazione/Acc. Dept.:

Tel. +39 0823 95 89 91
+39 0823 95 89 92
+39 0823 95 81 77
Fax +39 0823 95 69 49

Vendite/Sales Dept.:

Tel. +39 0823 95 89 84
+39 0823 95 81 76
+39 0823 95 89 85
Fax +39 0823 95 80 41

Spedizioni/Delivery Dept.:

Tel. +39 0823 95 81 66
Fax +39 0823 95 80 39



www.sintersud.com
info@intersud.com